

Information for the installer

INSTALLATION PROCEDURE:

1. Check that the wall is strong enough to hold the weight of the radiator. If replacing an existing radiator, you should cover and protect the flooring.
2. If replacing your existing radiator, undo the nuts that hold the valves onto the radiators. Ensure you have a container and drain any water inside. Ensure heating system and boiler are off before draining radiator.
3. Mark your preferred bracket positions based on lug locations (see right for lug locations) on the wall and drill holes for the fixings you intend to use. You will need to ensure you use suitable fixings for the wall type to which the radiator will be mounted. Fixings are not provided. If you are replacing your radiator, you should use new brackets.
4. Push fit the anti-vibration clips, provided in your accessory kit on to the brackets (see FIG. 1).
5. Screw the bracket to the wall using appropriate fixings (not provided) (see FIG.2).
6. Use a spirit level to check brackets are level and if so, mount the radiator onto the brackets (see FIG. 3 & 4).
7. Fit blanking plug and vent into the 2 connections which are not connected to the heating system. Where possible, place vent at the top.
8. Fit radiator valve tails into the flow and return connections and tighten firmly with a spanner.
9. Connect the radiator valves (not supplied) and fill the system.
10. Flush the entire system with an approved central heating cleanser and then refill using an approved central heating protector.
11. Run the system up to full temperature and release any trapped air using the air vent plug to complete installation, then switch system on.
12. For radiators <500mm HIGH and <500mm LONG with plastic pipes, anti-lift clips are recommended (see FIG. 5)

Pressed Steel Panel Radiator

T10, T11, T20, T21, T22, T33

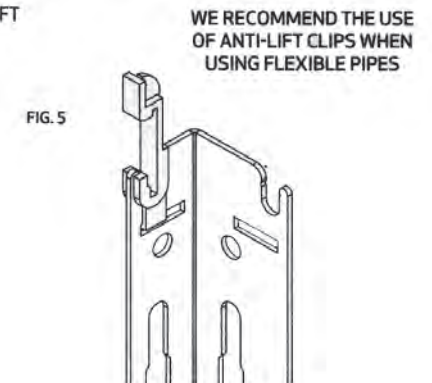
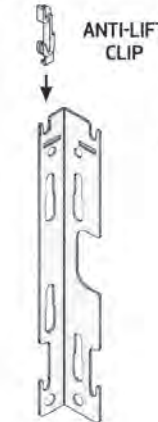
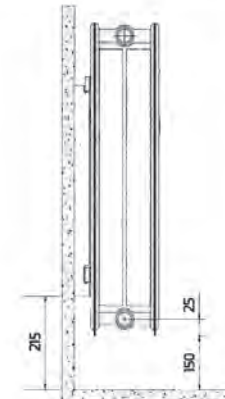
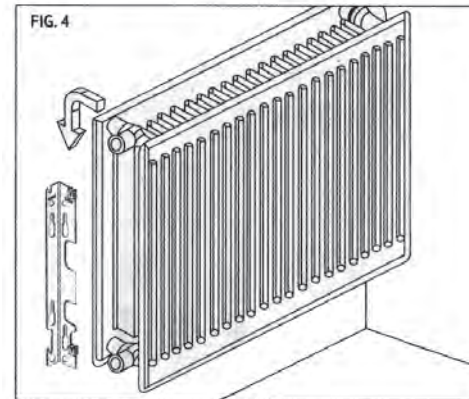
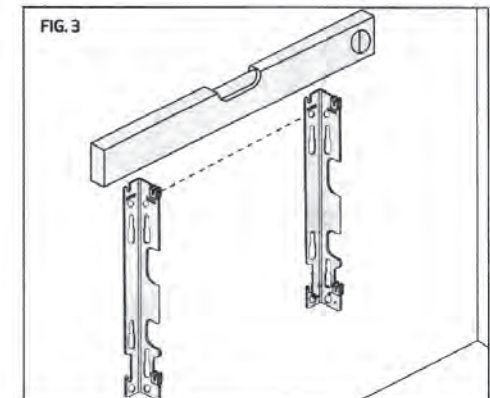
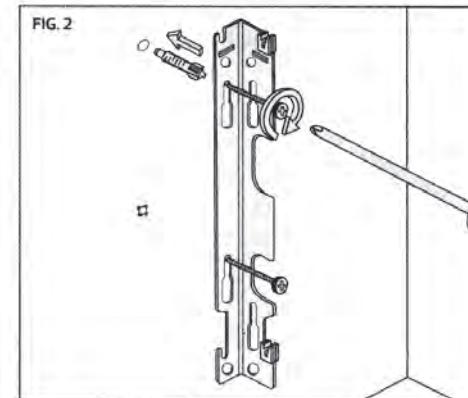
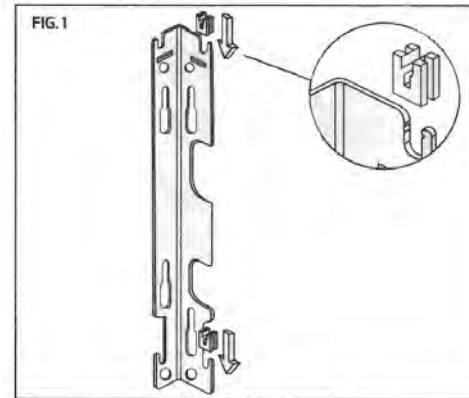

Additional support from L:1800
T10, T20, T21, T22 & T33 = Length/2
T11 = (Length/2) + 12mm

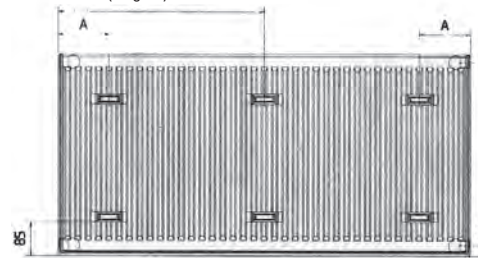

DIMENSION	TYPE	LENGTH(mm)	DISTANCE(mm)
A	T11	300	85
		400	135
		500>	160
	T10, T20, T21, T22, T33	300	72
		400>	122

Information for the installer

IMPORTANT NOTES:

- Ensure there is no trapped air in the radiator by adequately bleeding the system during installation.
- Flow rate may need to be adjusted/balanced for optimum performance.
- Wall fixings are not provided.
- Valve is not supplied.

General information. The installation and commissioning of the system should comply with BS EN 14336:2004. On completion of the installation, the system should be properly flushed and filled in accordance with the British Code of Practice for the Treatment of Water in Domestic Hot Water Central Heating Systems (BS 7593:2006). We strongly recommend the use of a corrosion inhibitor. Failure to comply with these standards might invalidate the manufacturer's warranty.

All dimensions are in mm.

International Head Office

QRL Radiator Group, Imperial Park, Newport, South Wales, NP10 8FS, UK.

Tel: +44 (0) 1633 657 000

www.qrl-radiators.com

www.merriottuk.com

www.merriott.ie

Pressed Steel Panel Radiator

T10, T11, T20, T21, T22, T33

TYPE 10



TYPE 11, 20, 21, 22, 33



RADIATOR HEIGHT	BRACKET HEIGHT
300	137
400	237
500	337
600	437
700	537
900	737

TYPE 20

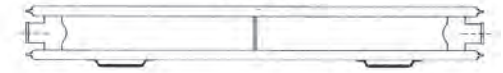

TYPE 21

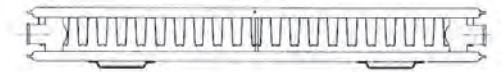

TYPE 22



TYPE 33

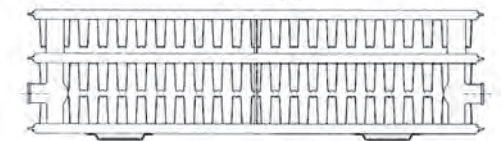

BLANKING PLUG



AIR VENT



TYPE 10



TYPE 11



TYPE 10

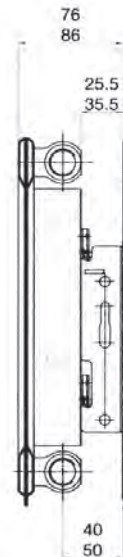

TYPE 11

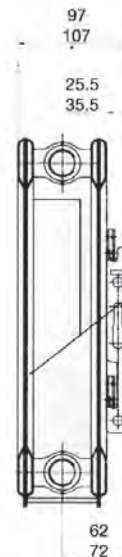

TYPE 20/21

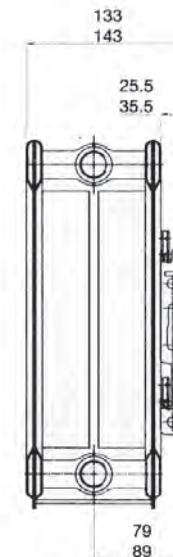

TYPE 22

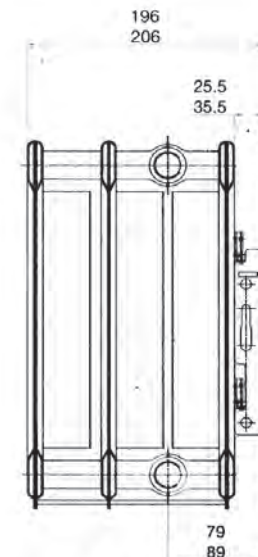

TYPE 33